

### Screw specifications

Part Number	Xsize	Lsize	Internal tooth
A/C/E	4.8	7.0	4#40
B/D/F	5.8	7.0	4#40
G	4.8	10.2	4#40
H/I	4.8	8.2	4#40

Explain:

- characteristic:  
 Rated voltage :250V AC max  
 Rated current :Maximum 3A  
 Contact impedance :30mΩ MAX.  
 Insulation impedance :3000MΩ MIN. at 500V DC  
 Withstand voltage value :250V AC RMS for 1Minute  
 working temperature : -45℃~+85℃
- Material Science:  
 Rubber core : PBT rated  
 Terminal : copper alloy  
 Housing : SPCC or copper alloy or stainless steel nickel plating or passivation treatment  
 Harpoon : SPCC or copper alloy, tin plated  
 Rivet : Copper alloy, nickel plated  
 Screw : Iron bar or copper alloy, nickel plated

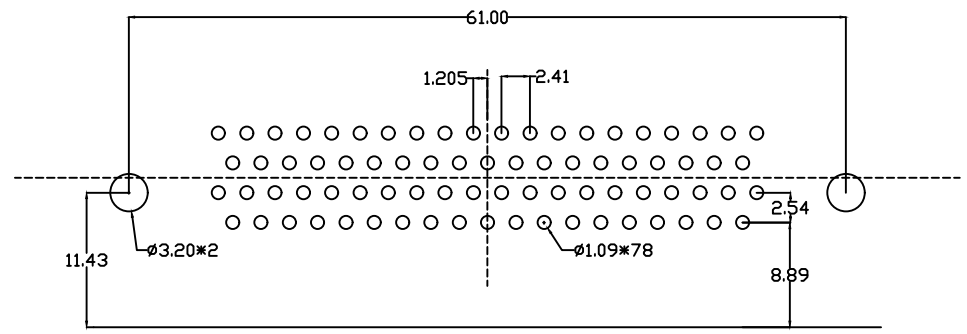
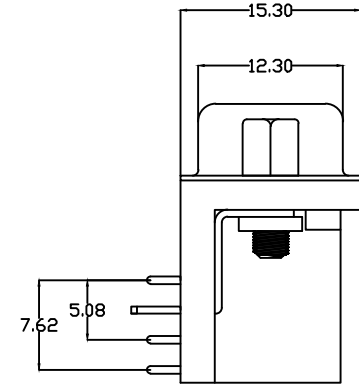
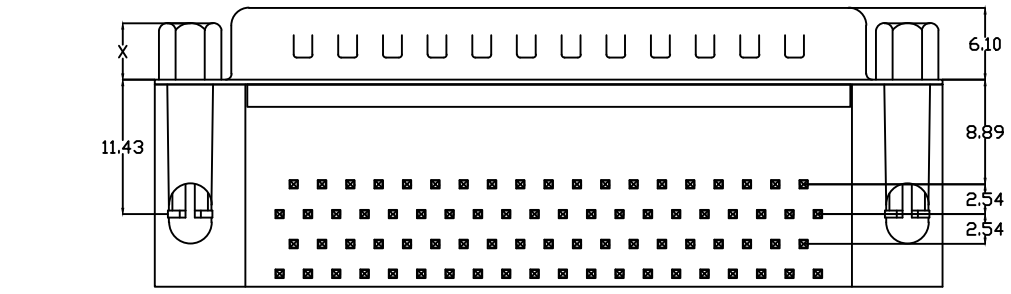

105C 78 M W 2 X XX X X A X  
 1 2 3 4 5 6 7 8 9 10 11

- Serial number:  
105C=HDR8.89 Riveting lock punch
- PIN distinguishing:  
15=15PIN 26=26PIN 44=44PIN 62=62PIN 78=78PIN
- Male female distinction:  
F=female M=male
- Traditional simple distinction:  
C=tradition J=simple and easy  
W=Simple without distinguishing tradition
- Plastic division:  
2=PBT black glue flame retardant
- Electroplating division:  
A=Semigold tin G=All gold
- Plating Thickness:  
00=0.6u-0.8u gold 01=1u gold 02=2u gold....  
Gold note: if the product is a semi gold tin 00 number, those representing the number of u of gold, the rest are tinned by default 80u-110u
- Enclosure differentiation:  
A=iron 12H B=iron 24H C=iron 48H D=Copper shell  
E=Stainless steel passivation  
F=Stainless steel nickel plating G=Gold plated iron shell
- Harpoon distinction:  
1=Iron harpoon 12H 2=Iron harpoon 24H 3=Copper harpoon  
5=No harpoon
- Rivet differentiation:  
A=5.4\*5.1\*1.2 Square rivet
- Screw differentiation:  
A=4.8 Iron screw B=5.8 Iron screw C=4.8 Copper screw  
D=5.8 Copper screw E=4.8 Gold plated iron screws  
F=5.8 Gold plated iron screws G=4.8\*15.0 Iron screw  
H=4.8\*13.0 Iron screw I=4.8\*13.0 Copper screw

UNLESS OTHERWISE SPECIFIED TOLERANCE

ANG.	±5'
0.	±0.5
.0	±0.3
.00	±0.2

**QIANGTS** 深圳市強泰盛電子有限公司  
 Shenzhen Qiangtaisheng Electronic Co. LTD.  
 TEL:86-755-82599792 FAX:86-755-27313473

SCALE: AS SHOWN	UNIT: mm
DRAWN WAN	07/07/08
CHECKED CHEN	07/07/08
APPROVED CHEN	07/07/08

DRAWN NAME: HDR78 male rivet lock  
 PRODUCT NO. 105C78MW2XXXXXX  
 FILE NAME: 105C78MW2XXXXXX

REV.	DESCRIPTION	DATE
A	ECN-20130617001(WAN)	06/17/13