

P.C.B LAYOUT

Explain:

- Characteristic:
 - Rated voltage :500V AC MIN
 - Rated current :5A
 - Contact impedance :30mΩ MAX.
 - Insulation impedance :3000MΩ MIN. at 500V DC
 - Withstand voltage value :500V AC RMS for 1Minute
 - Scope of work : -55°C~+105°C
 - Shell salt spray : Above 48H
- Material Science:
 - Rubber core : PBT rated
 - Car PIN : copper alloy
 - Housing : ferroalloy/copper alloy/Stainless steel
 - front shell nickel plating and rear shell tin plating/passivation
 - Bracket : ferroalloy, copper alloy, plate with nickel
 - Harpoon : Copper alloy, tin plated
 - Rivet : Copper alloy, nickel plated
 - Screw : ferroalloy/Copper alloy, nickel plated
 - Baffle : PA9T, yellow

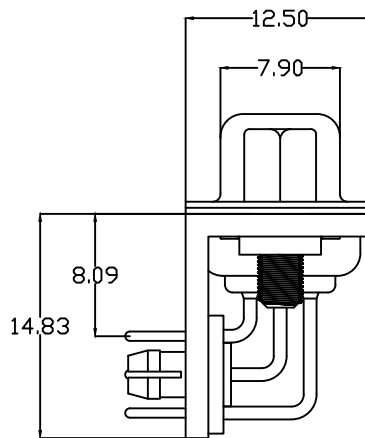
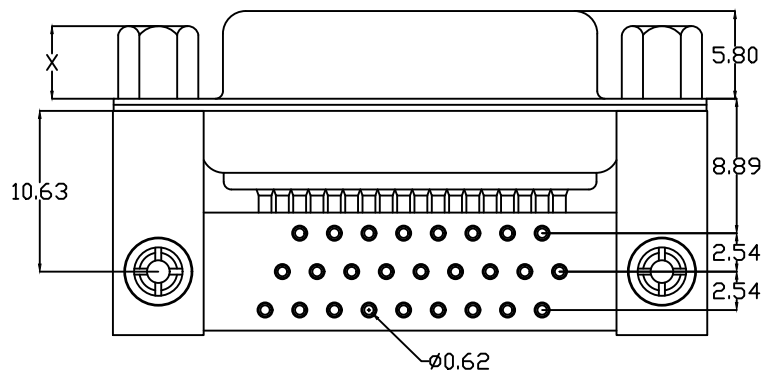

106G 26 F X X XX C X X 4 B X
1 2 3 4 5 6 7 8 9 10 11 12

- Serial number:
 - 106G=HDR needle riveting lock
- PIN distinguishing:
 - 15=15PIN 26=26PIN 44=44PIN
 - 62=62PIN 78=78PIN
- Male female distinction:
 - F=female M=male
- Plastic division:
 - 1=PBT White glue 2=PBT Black glue
- Terminal material differentiation:
 - H=brass P=Phosphor copper
- Terminal electroplating μ Numerical differentiation:
 - 01=1u gold AA=1.5u gold 02=2u gold....
- Terminal specification differentiation:
 - C=routine
- Enclosure differentiation:
 - 1=Iron shell 2=Copper shell 3=Stainless steel passivation
 - 4=Stainless steel nickel plating
- Support differentiation:
 - D=10.63 Iron support with plate
 - J=10.63 Copper bracket with plate
- Harpoon distinction:
 - 4=Four prong harpoon
- Rivet differentiation:
 - B=5.4*4.4*1.2 rivet
- Screw differentiation:
 - A=4.8 Iron screw B=5.8 Iron screw
 - C=4.8 Copper screw D=5.8 Copper screw

Screw specifications

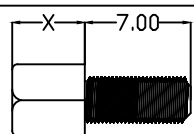

Part Number	Xsize	Internal tooth
A/C	4.8	4#40
B/D	5.8	4#40

UNLESS OTHERWISE SPECIFIED TOLERANCE	
ANG.	±5°
0.	±0.5
.0	±0.3
.00	±0.2



深圳市强泰盛电子有限公司
Shenzhen Qiangtaisheng Electronic Co. LTD.
TEL:86-755-82599792 FAX:86-755-27313473

SCALE: AS SHOWN	UNIT: mm
DRAWN WAN	06/17/13
CHECKED CHEN	06/17/13
APPROVED CHEN	06/17/13

DRAWN NAME: HDR26 bus needle with plate riveting lock
PRODUCT NO. 106G26FXXXXCXX4BX
FILE NAME: 106G26FXXXXCXX4BX

REV.	DESCRIPTION	DATE
A	ECN-20130617001(WAN)	06/17/13